



Practical Manual

B.Sc. (Hons.) Agriculture
3st Semester

Farm Machinery and Power
(13AP.212)

Ex. No	Name of the Exercise	Page No.
1	Study of different Components of Internal Combustion (I. C.) Engine	3-4
2	Study the construction and working of air cleaning and cooling systems used in internal combustion (I.C.) engine.	5-6
3	Familiarization with clutch, transmission, differential and final drive of a tractor.	7-8
4	Familiarization with lubrication and fuel supply system of engine.	9-10
5	Familiarization with Brake, Steering, and Hydraulic Control System of a Tractor	11-13
6	Learning of Tractor Driving	14-16
7	Familiarization with operation of power tiller	17-23
8	Implements for hill agriculture	24-35
9	Familiarization with different types of primary and secondary Tillage implements: mould board plough, disc plough and disc Harrow.	36-48
10	Familiarization with Seed-Cum-Fertilizer Drill Seed Drill:	49-52
11	Familiarization with different types of sprayers and dusters	53-61
12	Familiarization with different Inter-Culturing Tools and Implements	62-64
13	Familiarization with Harvesting and Threshing Machinery	65-68

Practical No: 01

Study of different components of I.C. engine.

Aim:-To study the different components of an internal combustion (I.C.) engine, their construction, working, and functions.

Theory

An Internal Combustion Engine is a machine in which combustion of fuel takes place inside the cylinder to produce power. The power is developed by burning a mixture of fuel and air inside the combustion chamber, which drives the piston, crankshaft, and ultimately produces mechanical work.

Main Components of I.C. Engine:

1. **Cylinder Block** – Main body of engine containing cylinders and water jackets.
2. **Cylinder Head** – Closes the top of the cylinder and houses valves/spark plug.
3. **Piston** – Reciprocates inside the cylinder, transmits force of combustion to connecting rod.
4. **Piston Rings** – Provide sealing between piston and cylinder walls, prevent leakage.
5. **Connecting Rod** – Connects piston to crankshaft, converts reciprocating to rotary motion.
6. **Crankshaft** – Transforms reciprocating motion into rotary motion, transmits power.
7. **Flywheel** – Stores energy, maintains uniform rotation.
8. **Valves (Inlet & Exhaust)** – Control entry of charge and exit of exhaust gases.
9. **Camshaft** – Operates valves at correct timing.
10. **Carburetor / Fuel Injector** – Supplies air–fuel mixture in spark ignition (SI) or injects fuel in compression ignition (CI) engines.

11. **Spark Plug / Fuel Injector Nozzle** – Initiates combustion (SI) or sprays fuel (CI).
12. **Crankcase** – Encloses crankshaft, provides support and lubrication.
13. **Cooling System** – Maintains engine temperature (air or water cooling).
14. **Lubrication System** – Reduces friction and wear between moving parts.

Observation Table

Component	Location	Function
Cylinder Block	Main body of engine	Houses cylinder & cooling passages
Piston	Inside cylinder	Converts combustion pressure into motion
Connecting Rod	Between piston & crank	Transmits reciprocating motion
Crankshaft	Below cylinder block	Converts reciprocating motion to rotary
Flywheel	Attached to crankshaft	Maintains uniform speed
Inlet Valve	Cylinder head	Allows air/fuel mixture inside
Exhaust Valve	Cylinder head	Releases burnt gases
Spark Plug / Injector	Cylinder head	Ignition / fuel injection

Practical No:02

Aim:-To study the construction and working of air cleaning and cooling systems used in internal combustion (I.C.) engine.

Theory

Air Cleaning System

Engines require clean air for efficient combustion. Dust and dirt in intake air cause wear of cylinder, piston rings, and valves. **Air cleaners** remove dust before the air enters the carburetor/fuel injector.

Types of Air Cleaners:

1. **Oil Bath Type Air Cleaner** – Air passes through an oil reservoir; dust particles get trapped in oil.
2. **Dry Type Air Cleaner** – Uses filter elements (paper/foam) to remove dust.
3. **Wet Type Air Cleaner** – Uses wet materials (like wire mesh soaked with oil) to trap dirt.

Cooling System

During combustion, engine parts become very hot. To prevent overheating, a cooling system is required.

Types of Cooling Systems:

1. **Air Cooling System** – Fins are provided on the cylinder block and head; air absorbs heat as it flows over fins (common in motorcycles, scooters).
2. **Water Cooling System** – Water circulates around the cylinder block through jackets. Heat from water is dissipated by a radiator and fan.

Methods of Water Cooling:

- **Thermo-syphon system** – Water circulates naturally due to density difference.
- **Pump circulation system** – Water pump circulates coolant.
- **Radiator cooling with fan** – Improves cooling efficiency.

Procedure

1. Observe the engine model and locate the air cleaner.

2. Identify the type of air cleaner and study its construction.
3. Trace the path of air entering the carburetor/injector through the air cleaner.
4. Locate the cooling system (air fins or water jackets).
5. For water cooling: trace flow of water from pump → cylinder jackets → radiator → reservoir.
6. For air cooling: observe arrangement of fins and fan.
7. Record functions of each system in the observation table.

Observation Table

System	Type	Main Components	Function
Air Cleaning	Oil Bath	Oil reservoir, mesh	Dust removed by oil
Air Cleaning	Dry Type	Paper/foam filter	Dust filtered mechanically
Cooling	Air Cooling	Fins, blower/fan	Heat removed by air
Cooling	Water Cooling	Pump, radiator, jackets	Heat removed by water circulation

Precautions

- Handle the model carefully; do not forcefully dismantle components.
- Ensure the direction of airflow and coolant flow is correctly traced.
- Avoid touching radiator fins with hands (sharp edges).
- Record only actual observations, not assumptions.

Practical No:03

Familiarization with clutch, transmission, differential and final drive of a tractor.

Aim:-To study and understand the construction, working, and functions of clutch, transmission system, differential, and final drive of a tractor.

Theory

1. Clutch

- A clutch is a device that connects and disconnects the engine power from the transmission system.
- It allows smooth starting, gear changing, and prevents jerks.

Types used in tractors:

- Single plate clutch
- Multi-plate clutch
- Cone clutch
- Centrifugal clutch

2. Transmission System

- Transmission transmits power from engine to wheels with desired torque and speed.
- It consists of gearbox, shafts, and gear selectors.
- Tractor transmission generally has multiple forward gears and reverse gears for field operations.

3. Differential

- A differential allows the rear wheels to rotate at different speeds when turning.
- It splits torque between left and right wheels.
- Prevents skidding during turns.

4. Final Drive

- Final drive further reduces speed and increases torque before transmitting power to wheels.

- It provides mechanical advantage for heavy-duty work in agriculture.
- Common types: Spur gear final drive, Planetary final drive.

Procedure

1. Observe the tractor model provided in the lab.
2. Identify the **clutch assembly** and note how it connects engine to gearbox.
3. Locate the **transmission/gearbox** and trace the power flow through different gears.
4. Study the **differential mechanism**, rotate wheels, and observe how they rotate at different speeds during turning.
5. Examine the **final drive assembly** and note its connection to rear wheels.
6. Record all observations in the table.

Observation Table

Component	Location	Function
Clutch	Between engine & gearbox	Engages/disengages power flow
Transmission (Gearbox)	Between clutch & differential	Provides variable speed & torque
Differential	Between gearbox & final drive	Allows wheels to rotate at different speeds
Final Drive	Between differential & wheels	Reduces speed, increases torque

7. Precautions

- Do not start tractor engine inside lab without permission.
- Observe components carefully without dismantling unless instructed.
- Avoid touching rotating parts during demonstration.
- Ensure safety while handling cut-section models.

Practical No:04

Familiarization with lubrication and fuel supply system of engine.

Aim:-To study the construction, working, and functions of lubrication and fuel supply systems used in internal combustion (I.C.) engines.

Theory

A. Lubrication System

Lubrication reduces **friction, wear, and overheating** of engine parts. It also helps in cooling, sealing, and cleaning.

Types of Lubrication Systems:

1. **Splash System** – The rotating crank splashes lubricating oil to lubricate parts (used in small engines).
2. **Pressure Feed System** – Oil pump circulates oil under pressure to bearings and moving parts (used in cars, tractors).
3. **Combination System** – Combination of splash and pressure lubrication.

Main Components:

- Oil sump
- Oil pump
- Oil filter
- Oil galleries/passages
- Pressure gauge

B. Fuel Supply System

1. Fuel Supply in Petrol Engine (SI Engine):

- Fuel tank → Fuel line → Fuel pump → Carburetor → Inlet manifold → Cylinder
- **Carburetor** mixes fuel with air in proper proportion before sending it to the engine.

2. Fuel Supply in Diesel Engine (CI Engine):

- Fuel tank → Fuel filter → Fuel injection pump → High-pressure fuel line → Injector → Cylinder
- **Fuel injection system** ensures proper atomization of diesel directly inside the combustion chamber.

5. Procedure

1. Observe the lubrication system model of the engine.
2. Identify oil sump, oil pump, oil filter, and flow passages.

3. Trace the path of lubricating oil from sump → pump → filter → bearings → return sump.
4. Observe the fuel system in petrol engine and trace path from tank → carburetor → cylinder.
5. Observe the fuel system in diesel engine and trace path from tank → filter → pump → injector → cylinder.
6. Record all observations in tabular form.

6. Observation Table

System	Component	Function
Lubrication	Oil Pump	Circulates oil under pressure
Lubrication	Oil Filter	Removes impurities from oil
Lubrication	Oil Sump	Stores lubricating oil
Fuel (Petrol)	Carburetor	Mixes air & fuel
Fuel (Diesel)	Fuel Injection Pump	Pressurizes fuel for injection
Fuel (Diesel)	Injector	Atomizes fuel into combustion chamber

7. Precautions

- Handle engine model carefully.
- Do not rotate shafts or pumps forcefully.
- Ensure correct tracing of oil and fuel flow lines.
- Do not touch sharp edges of cut-section parts.

Practical No:05

Familiarization with Brake, Steering, and Hydraulic Control System of a Tractor

Aim:-To study the construction, working, and functions of brake system, steering system, and hydraulic control system of a tractor.

Theory

A. Brake System

Brakes are devices used to slow down or stop the motion of a tractor by converting kinetic energy into heat energy.

Types of Brakes in Tractors:

1. **Mechanical Brakes** – Operated by linkage or rods.
2. **Hydraulic Brakes** – Operated by hydraulic fluid pressure.
3. **Disc and Drum Brakes** – Depending on design.

Functions:

- Provide control over tractor speed.
- Ensure safety during operation.
- Hold tractor stationary on slopes.

B. Steering System

Steering provides directional control of the tractor.

Types:

1. **Manual Steering** – Mechanical linkages transfer force from steering wheel to front wheels.
2. **Power Steering** – Uses hydraulic pressure to reduce steering effort.

Main Components:

- Steering wheel
- Steering shaft
- Steering gear box
- Drag link and tie rod

- Front wheels

C. Hydraulic Control System

The hydraulic system is used to operate tractor-mounted implements such as plough, harrow, seed drill, etc.

Main Components:

- Hydraulic pump (gear/piston type)
- Hydraulic fluid reservoir
- Control valve
- Hydraulic cylinder and piston
- 3-point linkage system

Functions:

- Lifting, lowering, and holding mounted implements.
- Providing draft and position control.

Procedure

1. Observe the tractor and locate the brake pedals and brake mechanism.
2. Study the type of brake used and trace the force transmission (mechanical/hydraulic).
3. Observe the steering system: rotate steering wheel and note movement of front wheels.
4. Identify steering gearbox, drag link, and tie rod connections.
5. Study the hydraulic system: locate pump, reservoir, control valve, and 3-point linkage.
6. Trace oil flow from pump → control valve → hydraulic cylinder → return to reservoir.
7. Record observations in table.

Observation Table

System	Main Components	Function
Brake	Brake pedal, drum/disc, linkage	Stops/controls tractor motion
Steering	Steering wheel, shaft, gearbox, tie rod	Provides directional control
Hydraulic	Pump, reservoir, control valve, cylinder, linkage	Operates tractor-mounted implements

Precautions

- Do not operate steering or brake forcefully on stationary tractor.
- Do not touch hydraulic connections under pressure.
- Observe cut-section models carefully; avoid dismantling without guidance.
- Ensure safety during live demonstrations.

Practical No:06

Learning of Tractor Driving

Aim:-To learn the basic driving techniques of a tractor and understand the operation of its main controls for safe handling.

Theory

The tractor is the most important power source in modern agriculture. Learning to drive a tractor includes understanding its **controls, transmission, braking, and steering system**, along with **safe operating practices**.

Main Tractor Controls:

- **Clutch Pedal** – Engages/disengages engine power.
- **Brake Pedals** – Stops or slows the tractor.
- **Steering Wheel** – Provides directional control.
- **Gear Lever** – Changes speed/torque.
- **Throttle Lever** – Controls engine speed.
- **Hand Brake** – Holds tractor stationary.
- **Hydraulic Control Lever** – Raises/lowers implements.
- **Ignition Switch/Starter** – Starts the engine.

Procedure

A. Familiarization

1. Identify all the tractor controls (clutch, brakes, steering, gear lever, throttle, hydraulics).
2. Sit on the operator's seat and adjust for comfort.
3. Ensure tractor is in neutral gear before starting.

B. Starting the Tractor

1. Depress clutch pedal fully.
2. Ensure gear lever is in **neutral** position.
3. Turn ignition key or operate starter to start the engine.
4. Warm up engine at low throttle.

C. Driving Practice

1. Depress clutch and engage **1st gear** slowly.
2. Release clutch gradually while increasing throttle.
3. Drive tractor straight for some distance at slow speed.
4. Practice steering turns (left and right).
5. Apply brakes smoothly to stop.
6. Practice changing gears from **1st to 2nd, 3rd, and reverse** under instructor's guidance.
7. Operate hydraulic lever to raise/lower implements (if attached).

D. Stopping the Tractor

1. Depress clutch and shift gear to **neutral**.
2. Apply brakes gradually.
3. Lower implements to ground (if raised).
4. Pull handbrake to lock wheels.
5. Turn off ignition switch.

Observation Table

Control	Location	Function
Clutch Pedal	Left foot pedal	Connects/disconnects engine power
Brake Pedals	Right foot pedals	Slows/stops tractor
Steering Wheel	Front	Controls direction
Gear Lever	Right side of seat	Changes speed/torque
Throttle Lever	Near steering	Controls engine speed

Control	Location	Function
Hydraulic Lever	Beside seat	Raises/lowers implements
Hand Brake	Beside seat	Holds tractor when stationary

Precautions / Safety Rules

- Always start tractor in **neutral gear**.
- Do not drive at high speed in the field.
- Avoid sharp turns at high speed.
- Do not allow extra passengers on tractor.
- Always lower implements to ground before leaving tractor.
- Wear proper footwear and avoid loose clothing.
- Follow instructor's guidance at all times.

Practical No: 07

Aim:-Familiarization with operation of power tiller

Study of Power Tiller- Important Parts and Attachments

Power Tiller: It is a prime mover in which the direction of travel and its control for field operation is performed by the operator walking behind it. It is also known as Hand Tractor or walking type tractor. The operator walks behind the power tiller, holding the two handles of power tiller in his own hands. Power tiller may be called a single axle walking type tractor, though a riding seat is provided in certain designs. Components of power tiller A power tiller consists of the following main parts.

- 1.Engine.
- 2.Clutch
3. Transmission gears
- 4.Brakes
5. Rotary unit

All the power tillers are fitted with an I.C. engine. At present most of the power tillers are fitted with diesel engine. Only Iseki make have used kerosene engine. Other makers like Kubota, Mitsubishi, Krishi Yanmar and Satoh have used diesel engine in India.

Operation:

The main clutch is a lever on the handle. The lever can be shifted to on or off position while operating in the field. When the lever is shifted to on position, the power from the engine is transmitted through the main clutch to the various parts of the power tiller. When the lever is shifted to off position, the power from the engine is cut-off from the rest of the transmission.

Power transmission in power tiller

For operation of power tiller, the power is obtained from the I.C. engine, fitted on the power tiller. The engine power goes to the main clutch with the help of belt or chain. From main clutch, the power is divided in two routes, one goes to transmission gears, steering clutch and then to the wheel. The other component goes to the tilling clutch and then to the trilling attachment.

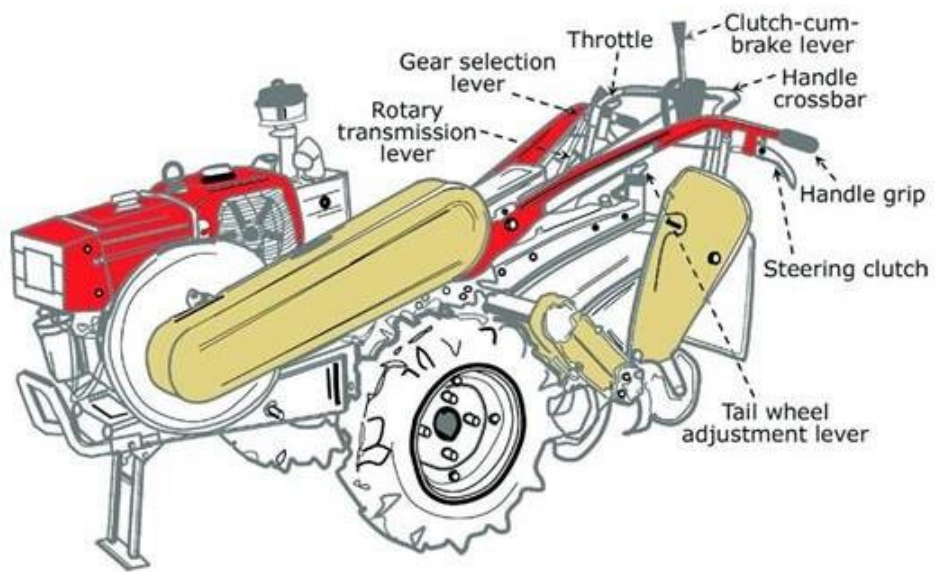

Name of parts	Name of parts
Handle grip	V-belt
Throttle lever	Tension pulley
Auxiliary handle	Main clutch pulley
Main gearshift lever	Belt cover
Hanger	Handle cover
Front stand operating lever	Handle cover grip
Auxiliary chain case set screw	Tine speed change lever
Auxiliary chain case	Main gear shift lever
Steering clutch lever (right)	Hand light

Rear wheel height adjusting lever	Lamp switch
Rear wheel pipe attaching handle	Steering clutch lever (left)
Ridger set screw	Steering clutch wire
Mud-guard (right)	Rubber guard
Side cover(right)	Protector
Tilling tines	Fender left
“Magic Bar”	Rubber tire
Front frame	Hexagon wheel tube
Protector	Side frame
Front lights	Tilling tines
Engine pulley	Rear wheel

The flow chart for transmission of power is given below.

V-belt is usually used to transmit power from the engine to the main clutch, because V-belt has very high efficiency and it works as a shock absorber also.

Main clutch

Power goes from the engine to the main clutch. Clutch may be a. Friction clutch or b. V-belt tension clutch Friction clutch is generally used for bigger power tiller. Usually it is a dry type multiple disc clutch. V-belt tension clutch is used for small power tiller.

The main functions of clutch in a power tiller are:

- a. b. to transmit engine power to transmission gears and
- b. to make power transmission gradual and smooth.

Transmission gears. Transmission box consists of gears, shafts and bearing. The speed change device may be: a. gear type or b. belt type

Brakes: All power tillers have some braking arrangement for stopping the movement. Most of the power tillers use inner side expansion, type brake

Wheels: Usually 2 to 4 ply pneumatic tyers are used in power tillers. The pressure of the tyre ranges from 1.1 to 1.4 kg/cm².

Rotary unit: Power tiller has a rotary unit for field operation Rotary unit is of two types:

1. Centre drive type and 2. Side drive type

1. Centre drive type ha got transmission at the center and the side drive type the transmission at one side.

Centre drive type has the following characteristics:

- a. Tilling width can be widened.
- b. Rotary unit is light in weight“
- c. Fixing of attachment is easy
- d. The tine shaft can be detached easily
- e.]Mounting and dismounting of rotary unit is very easy
- f. It may leave some portion of the field untilled
- g. It has one point support on the ground.

2. In side drive type:

- a) Deeper tilling is possible.
- b) The arrangement is useful for hard soil
- c) It has two point support on the ground

Rotary tines: Rotary tines are used in rotary unit for soil cutting and pulverization purpose.

Rotary tines are of three types:

- 1. Straight tines
- 2. curved tines and
- 3. Siding tines

In case of straight tines

- a. Power consumption is less
- b. Fine pulverization of soil is possible.
- c. Poor soil turning
- d. Grass entangles in the tines very easily.
- e. It is suitable for hard soil

In case of curved tines:

- a. Good soil turning is possible
- b. It is suitable for avoiding grasses
- c. Pulverization of soil is coarse and
- d. Power consumption is high.

Siding tines have the characteristics of sliding on their position according to the requirements

- a. the tines can be arranged in 3ways:
- b. Inner heap (to break the ridges)
- c. Outer heap (to make the ridges)and
- d. Even arrangement.

Steering clutch lever: Steering clutch is provide on the grip of the right and left handles. When the left side is griped, power is cut-off on left side of the wheel and the power tiller turns to the left. Similarly when the right side is griped, the power tiller turns to the right.

Rotary tilling A Plane Tilling: There are various ways of tilling by the rotary tiller, but the method most commonly used at present is the „every other row tilling“ method because it is very efficient and is very simple.

1. Every other row tilling method: Take the power tiller and put it into the paddy field which is to be tilled, and first till along the levee on the long side. Next, leaving a space which is little narrower than the tilling width (this depends upon the skill of the operator bur a width of about 3 to 6 cm) till the whole paddy field. In other words, the every other tow tilling method is tilling with a space between the tilling. After every other tow tilling method has been completed till the place which has not been tilled. In this case, the front wheels will pass over a place which has previously been tilled so it would sink a little, which in other words means that the tilling would be a little deeper than the previously tilled parts. Therefore, by the use of the rear wheel height adjusting lever, raise the rotary part a little so that the foundation of the tilling would be the same for both tilling. At the end, the headlands which have been left untilled should be tilled. When the headland is finished, the tilling job is finished.

2. Close by tilling method: In case by tilling method whole field is tilled in an orderly fashion, one row after another. This method requires a comparatively high skill so it is not commonly adopted. One of the wheels passes over a tilled plot.

A. Puddling : If a puddler and filed leveler is attached to the rear of the rotary tiller, it is possible to do efficient puddling work to a width of about 1.5 meter to 2 meter

B. Ridging: The ridger should be attached and adjusted in the power tiller. The following are some of the methods in doing riding work.

1. Ridge with core: Attach a ridger to the rotary tiller and make the ridges by doing ridging work together with the rotary work.

Advantages:

i. Drainage is very good in wet paddy fields

ii Very efficient

2. **Ridge by every other row method:** First make the rotary tilling tines face inwards and attach the ear two wheels, then till in the every other row method. When this is finished, turn the tilling tines outside and attach the ridger and make ridges on the untilled part.

Advantages: i. 3. The soil will be uniformly pulverized

ii. Machine proceeds very straight

iii. There is restriction on the width of the ridge.

4. Ridge after plane tilling: First till the whole plot of land by the ordinary rotary tilling method. In doing this take into consideration the progress of the ridge work to be done later and be very careful to proceed straight, next, turn the tilling tines outwards, set the ridger and do the ridging work.

Practical No: 08

Aim:-To study the Implements for hill agriculture

In the Upper Himalayas, varied topographic and agro-climatic conditions ranging *from* subtropical to cool temperatures permit the cultivation of a wide variety of crops and fruits. However, agriculture in general is handicapped due to steep and hilly terrain, hazards of climate, uneconomic scattered holdings comprising of shallow and stony soils. The tools and implements used are of a primitive nature throughout the Indian Himalayan range(s). Traditional farm tools and implements for self sustenance have been developed/modified through experience over generations to meet emerging socio-economic and farming challenges. The type of soils and topographic conditions largely influence the type, size and shape of particular tillage tools/implements. The following is a list of local tools/implements found in various regions of temperate Himalayas.

A brief discussion of the most commonly used indigenous implements are given in table 1.

Tillage implements

1. **Plough:** Tillage is the basic operation in farming. It is done to create favourable conditions for seed placement and plant growth. This is done mainly with a plough. A full history of the evolution of plough is not available. Farmers have been using plough since time immemorial. The primitive model might have been a crooked twig or a branch of a tree. The basic components of the plough are a shoe, a share, a body, a handle and a beam.

The shoe and body make one piece in the case of ploughs being used in Kullu, Solan, Shimla, Sirmour, Lahaul & Spiti and Kinnaur district of Himachal Pradesh. The Joint between the shoe and the body is purposely avoided with a view to make the plough more rigid and robust, so that the implement can work on gravely soils with stones and other obstacles which are encountered during the course of ploughing. (Figs. 9.1a, b & c)

Fig. 9.1a Traditional plough

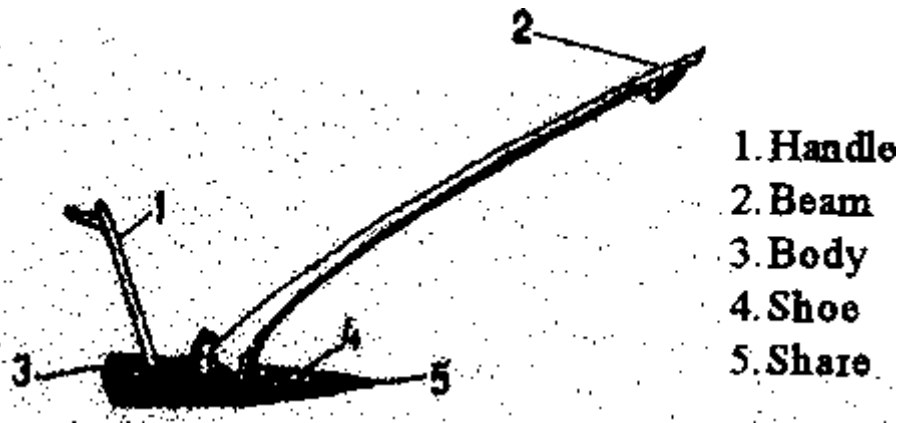
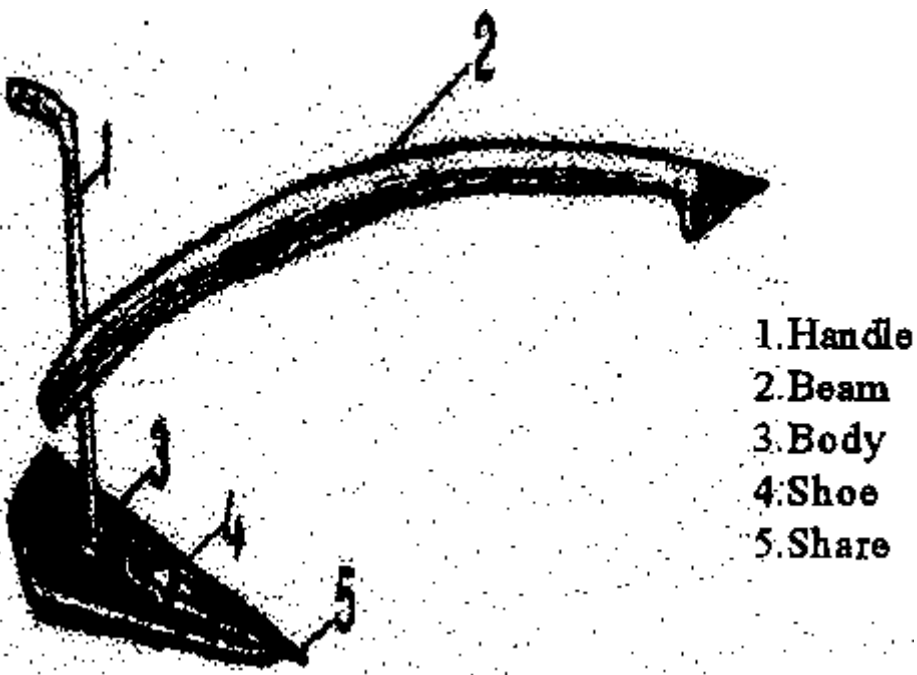
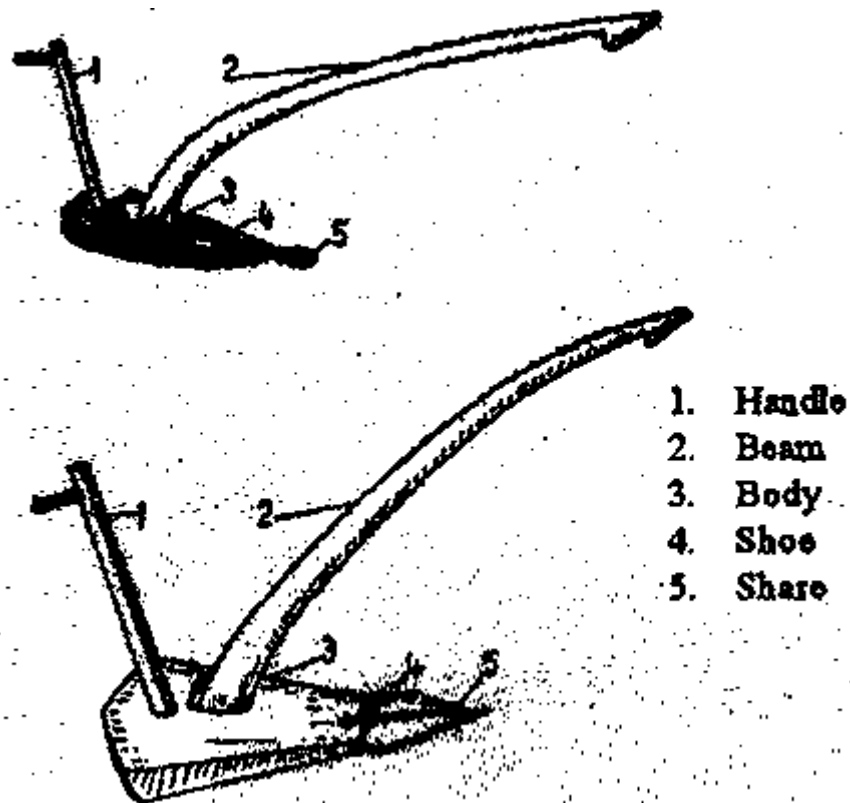

Fig. 9.1b Traditional plough



In another type, the shoe and body feature as separate parts (Fig. 9.1d). This type is particularly preferred in soils with a greater proportion of sand particles. This type of structure facilitates the replacement of the shoe when it wears out due to the abrasive action of the sand. This type of plough is used in Mandi, Chamba, Una and Kangra districts of Himachal Pradesh. In Sirmour district, the beam of the plough is joined to the handle instead of the body. This is done to provide more clearance under the beam and for easy passage over clods and stubble. The handle is 0.6 to 1 m long, 5 to 7.5 cm thick and 7.5 to 12.5 cm wide and is fitted to the body of the plough.

Fig. 9 1c & d Traditional plough



The shoe, used in the plough, can be of different shapes and sizes. Ploughs used in dry lands have shoes which are generally of a triangular section while in wet land cultivation the shoes are of a more flat section.

The share is prepared from a mild steel bar, 0.6 to 7.5 m in length and 1.5 to 2.5 cm in width. The share is fixed to the shoe or body by means of a U-clamp or ring shaped clamp. The share point projects beyond the shoe by 5 to 7.5 cm. Beams generally vary in length from 2.4 to 3 m.

2. **Yoke:** The yoke has a projection at the centre to which a beam of implements like plough, leveller and harrow etc. are secured by a rope (Fig. 9.2).

Fig. 9.2 Neck yoke (jungle)



3. **Leveller:** The plank of the leveller is made of any locally available wood and shafts are generally made of bamboo sticks. Extra weight is added to all type of

planks by placing stones on it or having person (s) ride on it. As the name suggests, levellers are used for levelling land (Fig. 9.3a & b).

Fig. 9.3a Leveller (Suhaga)

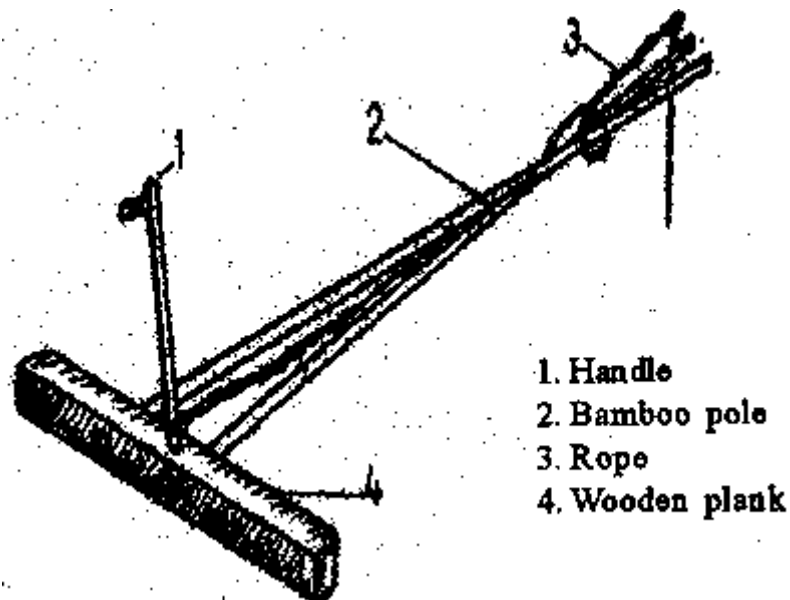
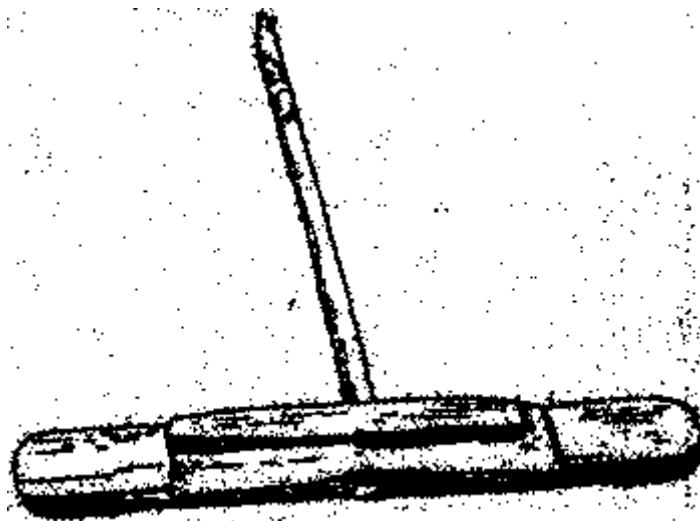

Fig. 9.3b Leveller (Suhaga)



4. **Harrow:** It has a wooden plank to which wood/iron pegs, handle and bamboo shaft are fitted. It is used for breaking soil crust after rain and also for uprooting weeds (Fig. 9.4).

5. **Mallet:** It has a wooden block to which a handle is attached. Occasionally, one end of the block is tapering. It is used for the breaking of clods (Fig. 9.5).

Interculture operation tools

1. **Khilna**: Its handle is made of a branch of sturdy wood and the tool itself is made of iron and is shaped like an arrowhead. It is used for uprooting of weeds (Fig. 9.6).

2. **Kudali**: Used for digging and weeding operations (Fig. 9.7), it is made of materials similar to the Khilna with the exception that the iron end is flat.

Fig. 4.4 Harrow (Dandal)

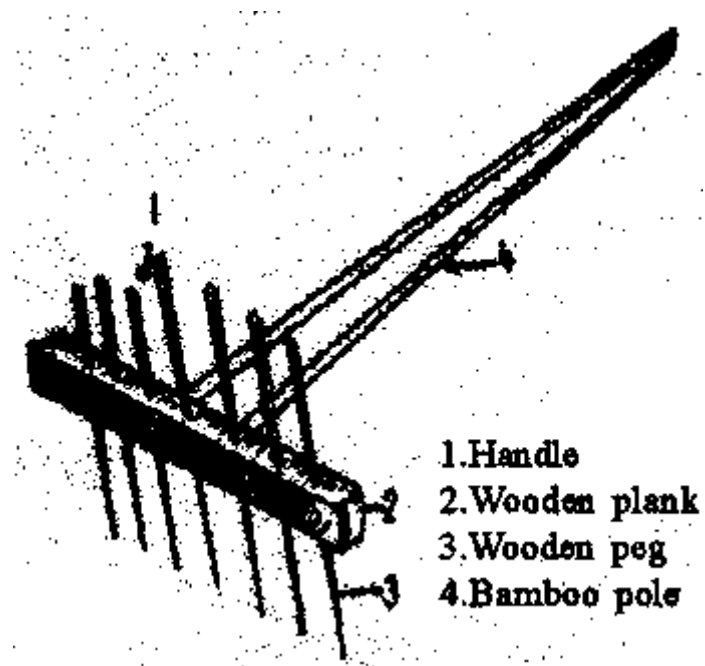

Fig. 9.5 Mallot

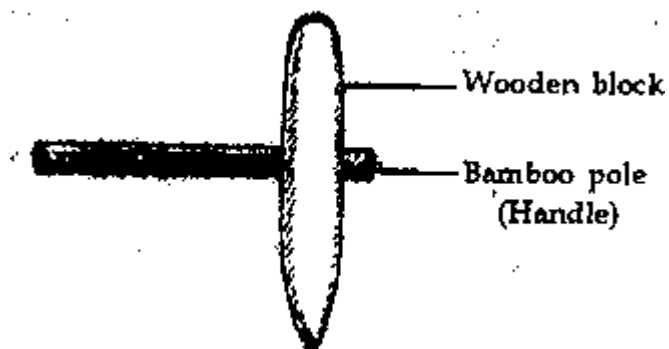

Fig. 9.6 Khilna

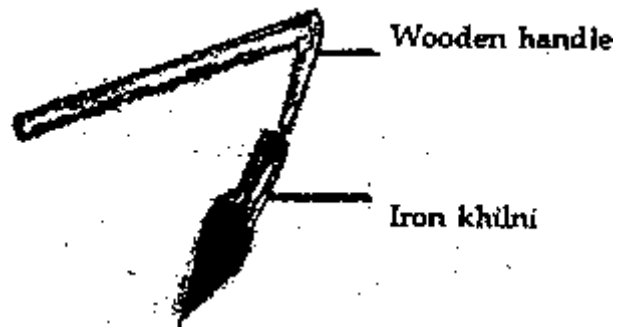
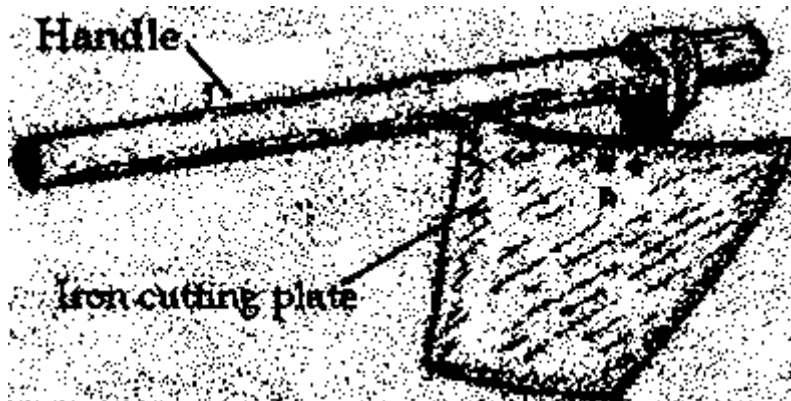

Fig. 9.7 Kudali



Fig. 9.8 Spade (Pharwa)



Harvesting tools:

The most common type of harvesting implement are small sickle, big sickle, *darat*, *gandasa* and small axe etc., (Fig. 9.9a, b, c & d).

Fig. 9.9a Small sickle (Daranti)

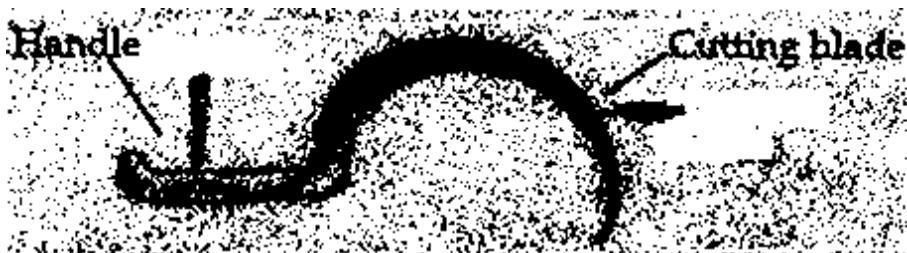

Fig. 9.9b Big sikle (Darati)



Fig. 9.9c Gandasa (Chopper)

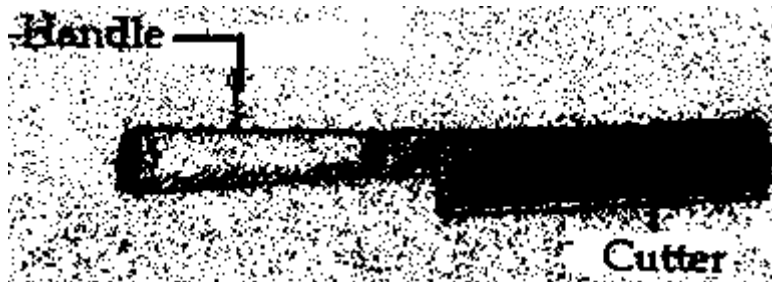
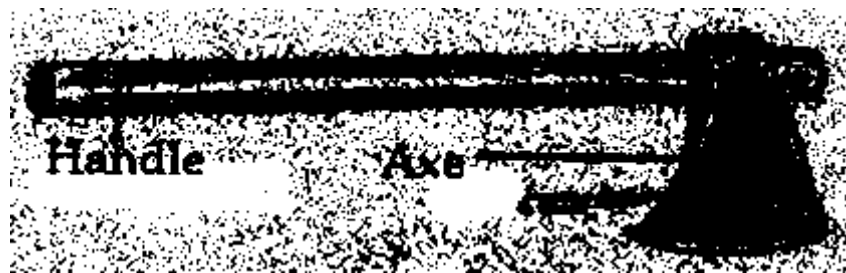

Fig. 9.9d Axe (Kulhari)



The hand sickle is used to harvest crops like wheat, maize, barley, pulses and grass etc. Big sickle (*Darat*) is used to harvest fodder from trees. *Gandasa* (*chopper*) and axe are used to harvest crops like sugar-cane etc.

Postharvest tools and implements

- 1. Wooden Pin:** Is used to remove the outer covering of maize cobs and is fashioned out of a bamboo stick.
- 2. Wooden Pole:** These are used to detach grains from the maize cobs and grains from other crops through a beating action.
- 3. Suhaga:** This is used to thresh both wheat and paddy crops according to traditional practice through the rubbing action of the *suhaga* with the tillers of crops.
- 4. Bamboo basket (*Kilta*):** This is used for carrying FYM and farm produce (Fig. 9.10).

Fig. 9.10 Big bamboo basket (Kilta)



5. Tokri (Fig. 9.11). A small bamboo basket.

Fig. 9.11 A small bamboo basket (Tokri)

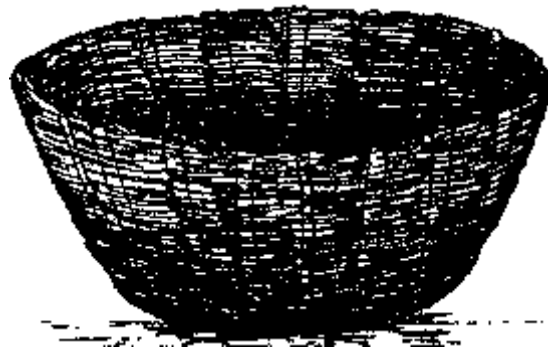

6. Hand mill: This is used to grind flour and pulses (Fig. 9.12).

Fig. 9.12 Indigenous hand mill



7. **Winnower:** This separates the grain from the husk (Fig. 9.13)

Fig. 9.13 Winnower (Shoop)

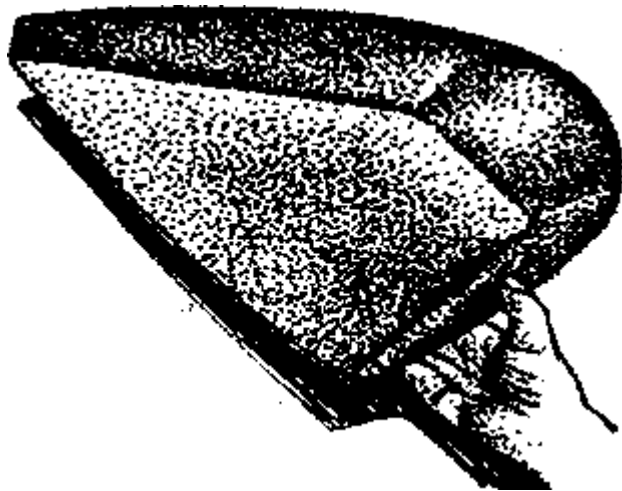

8. **Sieve:** This is used for the separation of different types of grains for elimination of alien material (Fig. 9.14).

Fig. 9.14 Sieve (Chanani)

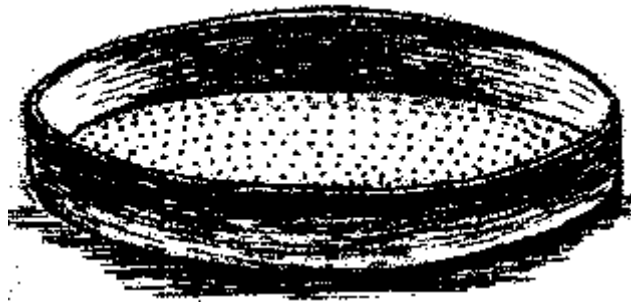

9. Sack: It is used to store the farm produce. 12. Pine needle collecting tool (Fig. 9.18). The traditional sack is made from the skin of sheep and goat (Fig. 9.15).

Fig. 9.15 Sack made of goat skin



10. Shearer: This is used for shearing wool (Fig. 9.16).

11. Skinner: This is used for taking off the skin of slaughtered goat/sheep (Fig. 9.17).

Fig 916 Sshearer (Balwan)



Fig 9 17 Sheep/goat skinner (Kataru)



12. Pine needle collecting tool (Fig. 9.18)

Fig. 9.18 Tool for collecting pine needles (Kadera)



Practical No: 09

Aim:-Familiarization with different types of primary and secondary Tillage implements: mould board plough, disc plough and disc Harrow.

Study of Primary Tillage Implements:

Mouldboard Plough and Disc Plough

A Mouldboard plough is very common implement used for primary tillage operations. The plough performs several functions at a time.

Function:

- 1) Cutting the furrow slice,
- 2) Lifting soil,
- 3) Turnings furrow slice and
- 4) Pulverizing soil.

Components:

M. B. plough consists of:

- a) Share,
- b) Mould board,
- c) Land side,
- d) Frog and
- e) Tail piece.

A) Share: It is that part of the plough bottom, which penetrates into the soil and makes a horizontal cut below the surface. Mould Board: It is the curved part, which lifts and turns the furrow slice. Land Side: It is the flat part, which bears against and transmits the rear side lateral thrust of the plough bottom to the furrow wall. Frog: It is the part to which other components of the plough bottom are attached. Tail Piece: It is an adjustable extension, which can be fastened to the rear of a Mouldboard to help in turning a furrow slice.

A. Shares: It penetrates into the soil and makes a horizontal cut below the soil surface. It is a sharp, well-polished and pointed component.

Different portions of the share are called by different names as:

- 1) Share point
- 2) Cutting edge
- 3) Wing of share
- 4) Gunnel
- 5) Cleavage edge and
- 6) Wing bearing.

1. Share Point: It is the forward end of the cutting edge, which actually penetrates into the soil.

2. Cutting Edge: It is the front edge of the share, which makes horizontal cut in the soil. It is beveled to some distance.

3. Wing of Share: It is the outer end of the cutting edge of the share. It supports the plough bottom.

4. Gunnel: It is the vertical face of the share, which slides along the furrow wall. It takes the side thrust of the soil and supports the plough bottom against the furrow wall.

5. Cleavage Edge: It is the edge of the share which forms joint between Mouldboard and share on the frog.

6. Wing Bearing: It is the level portion of the wing of the share, providing a bearing for the outer corner of the plough bottom.

Material of Share: The share is made of chilled cast iron or steel. The steel mainly contains about 0.70 to 0.80 % carbons and about 0.50 to 0.80 % manganese besides other minor elements.

B. Mouldboard: The Mouldboard is that part of the plough, which receives the furrow slice from the share. It lifts, turns and breaks the furrow slice. To suit different soil conditions and crop requirements, Mouldboard has been designed in different shapes.

C. Landside: It is the flat plate, which bears against and transmits lateral thrust of the plough bottom to the furrow wall. It helps to resist the side pressure exerted by the furrow slice on the Mouldboard. It also helps in stabilizing the plough while it is an operation. Landside is fastened to the frog with the help of plough bolts. The rear bottom end of the landside is known as heel, which rubs against the furrow sole.

D. Frog: Frog is that part of the plough bottom to which the other components of the plough bottom is attached. It is an irregular piece of metal. It may be made of cast iron for cast iron ploughs or it may be welded steel for steel ploughs.

E. Tail Piece: It is an important extension of Mouldboard which help is turning a furrow slice.

1. Indigenous Ploughs

It is one of the most common implements used by Indian Farmers.

The main parts of the plough are

- 1) Body Share Handle
- 2) Shoe
- 3) Share
- 4) Handle
- 5) Beam

1. The body is the main part of the plough to which the shoe, beam and handle are attached. The share is the working part of the plough and is attached to the shoe.

2. The shoe also supports and stabilizes the plough at the required depth. The beam is a long wooden piece which connected the main body of the plough to the Yoke. A wooden piece which is attached vertically to the body to enable the operator to control the plough is called the handle.

3. Mouldboard Ploughs

These ploughs are used in areas where there is sufficient rainfall to produce to good crop. It is also used to turn under the heavy growth of green manure crop to the proper decay and additions of humus to the soil.

Types of Mouldboard Ploughs

- 1 One way or Two way ploughs

Most of the walking type Mouldboard ploughs is one way ploughs, that is they are designed to throw the furrow slice to only one side in the direction of the motion.

2. Two way ploughs are suitable for terraced land of hilly tracts and have the advantages that they do not upset the slope of the land nor leave dead or back furrows in the middle of narrow fields. This is because the two bottoms are used alternately and the furrow-slices are thrown on the same side.

The two ways plough is also useful for ploughing irrigated land where it is required that the land be left without the depression of the dead furrows and ridges of back furrows. Some of the two way ploughs have a single bottom but the provision is made to change the direction of throw of furrow slice at the end of the plot where the bullocks turn. Such a plough is also known as Turn Wrest Plough.

3. Left hand or Right hand Ploughs

These names refer to the direction of the throw of the furrow slice. Most of the Mouldboard ploughs are right. Left hand type ploughs are rare in India because bullocks are trained to take turn on their left while ploughing. Plough Sizes The size of the Mouldboard is expressed by the width of furrow that it is designed to cut. It can be measured by measuring perpendicular distance from the wing of share to the land side. Plough Adjustment For proper penetration and efficient work by the Mouldboard plough, some clearance is provided in the plough this clearance is called "Suction" of the plough. Vertical Suction or Clearance is the maximum clearance under the landside and horizontal surface in the working position. It is the vertical distance from the ground, measured at the junction point of share and landside. It helps the plough to penetrating into the maximum horizontal clearance between the landside and the furrow slice. This clearance varies according to the size of the plough to maintain proper width of the furrow. Study of disc plough A disk plough is one of which cuts, turns and in some cases breaks furrow slices by means of separately mounted large steel disks. It works well in the conditions where m.b. plough does not work satisfactorily.

Advantages of Disk Plough

1. The soil which is too hard and dry for ploughing with m.b. plough can be ploughed to required depth by disk plough.
2. It works well in sticky soils than m.b. plough.

3. It is more useful for deep ploughing.
4. It can be used safely in stony and stumpy soil without much danger of breakage.
5. It works well in loose soils also without much clogging.

Disadvantages

1. It is not suitable for covering surface bush and weeds as that of m.b. plough
2. It leaves soil more in rough and cloddy conditions.
3. It is much heavier than m.b. plough for equal capacities

Terms Connected with Disk Plough

1. Disk- It is a circular, concave revolving steel plate use for cutting and inverting the soil.
2. Disk Angle- It is the angle of which place of the cutting edge of the disk is inclined to the direction of travel. This angle of good plough varies between 42° & 45°.
3. Tilt Angle- It is the angle at which the plane of cutting edge of the disk is inclined to a vertical line. It varies between 15° & 25°.
4. Concavity- It is the depth measured at the center of disk by placing its concave side on the level surface.

A. Standard Disk Plough It consists of steel disk of 60 to 80 cm diameter set at certain angle to the direction of travel. Disk is made of heat treated steel 1/16" to 3/8" thick edge of which is well sharpened. Concavity varies with diameter of a disk (Approximate values of concavity being 3" for 24" dia disk and 6.5" for a 18" dia. disk).

Weight of plough : Tractor drawn - Animal drawn - 180 to 540kg 32kg.
The scraper is provided to remove soil that tends to stick to working surface of the disk. Each disk revolves on a stub axle in a thrust bearing, carried at the lower end of a strong stand bolted to the plough beam. 25 Mounted type In this side thrust is taken by the wheels of tractor or sometimes rear wheel is fitted to take side thrust. Trailed type Side thrust is taken by the furrow wheel.

B. Vertical Disk

Plough It combines the principles of regular disk plough and disk harrow and used in shallow soil working in the soil (3” to 4”deep). It consists of frame, wheel arrangements, depth adjusting device are as Std. disk plough but the disks are fitted on single shaft and turn as on unit. The dia. of disk is smaller and varies between 50 to 60 cm. Disk angle ranges between 350 to 550. There may be 2 to 32 disks spaced about 30 cm apart. All disks are fixed to throw soil in one direction. This plough is preferred in wheat growing areas. Plough Adjustments Various adjustments done on disk plough are for controlling depth or width of ploughing and to increase pulverization.

These are achieved as under.

1. By decreasing the tilt angle penetration is improved in standard plough
2. By increasing the disk angle penetration is improved but width of cut is reduced.
3. By adding weights to the plough penetration is increased.
4. The disk should be well polished and sharp
5. The plough wheels should be properly adjusted to keep plough operating level
6. The angle between the frame and land wheel axle be adjusted for required width or cut.

Defect	Reason	Remedy
1. Low penetration	i) Blunt disk	Sharpen the inner edge of the disk.
	ii) Plough too light	Put additional load
	iii) More tilt angle	Set the tilt angle
2. Heavy draft	i) Blunt disk	Sharpen the edge
	ii) Furrow too wide	Reduce tilt angle
3. Excessive side draft	i) Improper hitching	Hitch properly
4. Less scouring by disk	i) Scraper not properly set	Adjust the scraper correctly
5. Uneven furrows	i) Disk angle changing	Set the disk angle
	ii) Loose bearings	Set the bearing

Problems

1. A farmer purchased a 35 HP wheel type tractor at a total cost of Rs.3,50,000 and three bottom plough with 30 cm bottom width at Rs.6000 only. The fuel consumption of the tractor was 6 lit/hr at the ploughing speed of 5 km ph. a) Calculate the area ploughed per hr. b) Determine cost of ploughing per hectare. Make necessary assumption if any.
2. Determine the horse power required to pull a four bottom 30 cm plough working to depth of 15 cm. The tractor is operating at a speed of 6 kmph. The soil resistance is 0.7 kg/cm².
3. Total draft of four bottom 40 cm M.B. plough when ploughing 17.5 cm deep at 5.5 km/hr. speed is 1700 kg. a) Calculate the unit draft in kg/cm² b) What is actual power requirement? c) If field efficiency is 75 % what is the rate of doing work in ha/hr.

Study of Secondary Tillage Implements- Harrows and Cultivators

Inter culturing: Breaking the upper surface of the soil, uprooting the weeds (unwanted plants), aerating the soil, thereby promoting the activities of microorganisms and making a good mulch, so that the moisture inside the crop field is properly retained from evaporation.

(1) Harrow Harrows are used to break the clods, pulverize the soil and cut the weed at the time of preparing seed beds. Some of the important functions are to prepare the seed bed, to cover seeds, to stir and spread FYM and fertilizers in the fields, to aerate the soil and to control the weeds.

There are several types of harrows in use such as

1. Disc Harrow
 2. Spring Tooth Harrow
 3. Spike Tooth Harrow and
 4. Other Harrows (e.g. peg tooth harrow)
1. Disc Harrow It is a harrow which performs the harrowing operations by means of a set of a number of sets of rotating steel disc, each set being mounted on a common shaft. Disc harrow is of two types, viz. tractor drawn and bullock drawn. Tractor Drawn Disc Harrow Disc harrow is found very suitable for hard ground full of stalks and grasses. It cuts the lump of soil clods and roots. Discs are mounted on one, two

or more axles which may be set at a variable angle to the line of motion. As the harrow is pulled ahead, the disc rotate on the ground.

Depending upon the arrangements of discs, disc harrows are divided into three classes.

1) Single action

2) Double action (Tandem) &

3) Offset

a. Single Action Disc Harrow It is a harrow with two gangs plough end to end, which throw the soil in opposite direction. The discs are arranged in such a way that right side gang throws the soil towards right and left side gang throws the soil towards left.

b. Double action (Tandem) Disc Harrow It is a disc harrow consisting of four gangs in which a set of two gangs follow behinds the set of the other two gangs, arranged in such a way that the front and back gangs throw the soil in opposite directions. It can be said that the two front gangs throw the soil outwards while the two rear gangs shift the soil inwards. Thus the entries field is worked twice in each trip. 28 c. Offset Disc Harrow It has got only gangs, fitted one behind the other. The soil is throws in both directions because discs of gangs face in opposite directions. It is very useful for orchards and gardens. The line of the pull is not in the middle hence it is called offset disc harrow. In offset disc harrow basic principle is that side thrust against the front gang is opposed by the side thrust of the rear gang.

Components of Disc Harrow

A disc harrow mainly consists of disc gang, gang both or arbor bolt, gang control lever, spool or spacers, bearings, transport wheels, scraper and weight box.

i. Disc

It is a circular, concave revolving steel plate used for cutting and inverting the soil.

ii. Gang

Each set of discs which are mounted on a common shaft is called gang.

iii. Gang bolt of Arbor bolt

It is a long heavy bar of square or circular section threaded at one end and square headed at the other end. A set of disc are mounted on this gang bolt.

iv. Gang Control Lever A lever which operates the angle mechanism of the disc harrow is called gang control lever.

v. Spool or Spacer The flanged tube mounted on the gang bolt between every two discs to prevent the lateral movement of the disc on the shaft is called spool or spacer.

vi. Bearing Bearing is essential to counteract the end thrust of the gangs due to soil thrust. vii. Transport wheel These wheels are provided for transport work on roads.

viii. Scraper It prevents the discs from clogging. It removes the soil sticking to the concave side of the discs.

ix. Weight box It puts additional weight on the implements there by it also helps in increasing the penetration of the disc in the soil.

Penetration of Disc Harrow

It is achieved by any one of the following ways

1. By increasing the gang angle
2. By adding additional weight,
3. By lowering the hitch point
4. By using the sharp edged discs of small diameter and lesser concavity
5. By regulating the optimum speed.

Care and Maintenance of Disc Harrow:

1. Bearing must be thoroughly greased at regular intervals. All the nuts and bolts must be checked daily before taking the implement to the field. Blunt edges of the discs should be sharp ended regularly. During slack season, the worn parts including bearings should be fully replaced. It is better to coat the outer and inner surfaces of the discs when the harrow is lying without use in slack season.

2. Animal Drawn Disc Harrow: Disc harrow is used for breaking clods while preparing seed beds. It has usually six or eight discs fixed in two gangs, each gang has three or four discs. There is a strong frame made of mild steel, on which gangs with the disc are mounted. As operator's seat is also provided on the frame. Usually transport wheels are provided for easy movement of the harrow from place to place. The size of the harrow is determined by the maximum width of cut of the soil. The disc harrow varies between 80 to 100 kg only.

The disc harrow mainly consists of :

- (i) Disc
- (ii) Gang frame
- (iii) Beam
- (iv) Gang angle mechanism
- (v) scraper
- (vi) Spacer (spool)
- (vii) Clevis
- (viii) Axle
- (ix) Middle type and
- (x) Bearings.

3. Spring Tooth Harrow It is a harrow with flexible teeth suitable to work in hard and stony soils. Spring tooth harrow is fitted with springs, having loops of elliptical shape. It gives spring action in working conditions. This type of harrow mainly consists of teeth, tooth bars, clamps, frame, clevis, lever and links. The spring steel teeth are fastened to the tooth bars by tooth clamps.

4. Spike Tooth Harrow

It is a harrow with peg shaped teeth of diamond cross section attached to a rectangular frame. It is used to break clods, stir the soil, uproot the weeds, level the ground, break the soil crust, and cover the seeds. Its principle use is to smoothen & level the soil directly after ploughing. Spike tooth type harrows may be of either rigid type or flexible type. The animal drawn spike tooth harrows are usually of rigid type. The tractor drawn harrows are usually of flexible type. Spike tooth mainly consists of teeth, tooth bars, clamps, guard braces, levers and hooks. The teeth are made of hardened steel. Tooth bars are made of wood or steel. All teeth are fastened rigidly to the tooth bar. Clamps are used to fasten teeth to the tooth bars tightly so as not to be loose while in operations. 30

(2) Cultivators

It is an implement for inter cultivation with laterally adjustable tines or discs to work between crop rows. This can be used for seedbed preparation and for sowing with seeding attachment. The tines may have provision for vertical adjustments also.

The cultivator can be:

- 1) Disc cultivator,
- 2) Rotary cultivator,
- 3) Tine cultivator.

1. Disc cultivator: It is a cultivator fitted with discs.

2. Rotary cultivator: It is a cultivator with tines or blades mounted on a power driven horizontal shaft.

3. Tine cultivator: It is a cultivator fitted with tines having shovels. The cultivator stirs the soil, and breaks the clods. The tines fitted on the frame of the cultivator enter deeply in the soil. A cultivator performs functions intermediate between those of plough and the harrow. Destruction of weeds is the primary function of a cultivator.

The following are a few important functions performed by a cultivator:

- i) Intercultural the fields.
 - ii) Destroy the weeds in the field. Aerate the soil for proper growth of crops. Conserve moisture by preparing mulch on the surface. To sow seeds when it is provided with sowing attachments
- . To prevent surface evaporation and encourage rapid infiltration of rain water into the soil.

Depending upon the type of power available for the implement, the cultivator can be classified as

- 1) Tractor drawn
- 2) Animal drawn.

1. Tractor Drawn Cultivator: It may be:

- i) Trailed
- ii) Mounted.

i. **Trailed Type Cultivator:** It consists of a main frame, which carries number of cross members to which tines are fitted at the forward end of the cultivator. There is a hitch arrangement for hitching purpose. A pair of wheels is provided in the cultivator. The lift is operated by both wheels simultaneously so that draft remains even and uniform. The height of the hitch is adjusted so that main frame remains horizontal over arrange of depth setting. The tines in each row are spaced widely to allow free passage of the soil and trash around them. The tines in subsequent rows are staggered so that the implement can cover the entire width nicely. The depth of working is set roughly by adjusting the tine in their clamps and the final depth control is done by a screw lever. Usually the types are damaged due to turning the implement at the headland without lifting it up. Care should be taken to lift the tines off the ground before turning.

ii. **Mounted Cultivator:** Tractors fitted with hydraulic lift operate the mounted type cultivators. A rectangular frame of angle iron is mounted on three point hydraulic linkage of the tractor. The cross members carry the tines in two staggered lines. For actual cutting the soil, different types of shovels and sweeps are used.

A few important shovels and sweeps are:

- (a) Single point shovel
- (b) Double point shovel
- (c) Sphear head shovel
- (d) Sweep
- (e) Half sweep
- (f) Furrow type.

Depending upon the type of soil and crop, shovels are chosen for use on the cultivators. Usually tractor drawn cultivators are of two types, depending upon the flexibility and rigidity of tines:

- (i) Cultivator with spring loaded tynes
- (ii) Cultivator with rigid tynes.

Cultivator with Spring Loaded Tynes

A tyne hinged to the frame and loaded with a spring so that its swings back when an obstacle is encountered is called spring loaded tyne. Each of the tyne of this type of cultivator is provided with two heavy coil springs. On passing

over the obstruction, the tynes are automatically reset and work continues without interruption. This type of cultivator is particularly recommended for soil which is embedded with stones or stumps.

The cultivator may be fitted with 7, 9, 11, 13 tynes or more depending upon the requirement. Cultivator with rigid tynes Rigid tynes of the cultivator are those which do not deflect during the work in the field.

Problems

1. How many acres can be covered by a harrow of width 1.5 m in a day of 8 hrs with bullock power? The speed of the bullocks it to be assumed. If each spike tooth harrow is giving 1 kg resistance when there are 50 spikes what HP would be necessary for the bullocks to pull the harrow with the assumed speed?

2 .A five tye cultivator having tynes spaced 8 cm a part and working to a depth of 5 cm is running at a speed of 3 kmph. There is a time loss of 10 per cent while turning. Calculate the time required to cultivate per hectare. If the resistance of the soil is 0.6 kg/cm^2 . What would be the maximum draft and HP required when the width of each furrow is 5 cm?

Practical 10

Familiarization with Seed-Cum-Fertilizer Drill Seed Drill:

Aim:-To study of Seed-Cum-Fertilizer Drill Seed Drill:

Seed drill is a machine for placing the seeds in a continuous flow in a furrow at uniform rate and at controlled depth with or without the arrangement of covering them with soil.

Function of Seed Drill: Seed drill performs the following functions:

- i. To carry the seeds.
- ii. To open furrow to a uniform depth.
- iii. To meter the seeds.
- iv. To place the seed in furrows in an acceptable pattern.
- v. To cover the seeds and compact the soil around the seed.

Seed-cum-fertilizer Drill: Seed drills, fitted with fertilizer dropping attachment, distribute the fertilizer uniformly on the ground. It is called seed cum fertilizer drill. Such a drill has a large seed box, which is divided length-wise into two compartments, one for seeds and another for fertilizers.

Seed drill may be classified as:

- i. Bullock drawn
- ii. Tractor drawn. Depending upon the method of metering the seeds, bullock drawn seed drill can be further divided into two groups.

Those in which seeds are dropped

(a) by hand,

(b) mechanically.

There are a number of bullock drawn implements, which are used for sowing seeds in which seeds are dropped by hand. The most popular implement is three tined cultivators with seeding attachment. In different parts of the country it is made in different sizes and shapes.

Components of Seed Drill:

A seed drill with mechanical seed metering device mainly consists of:

- i. Frame
 - ii. Seed box
 - ii. Seed metering mechanism
 - iv. Furrow openers
 - v. Covering device
 - vi. Transport wheels.
- i) **Frame:** The frame is usually made of angle iron with suitable braces and brackets. The frame is strong enough to withstand all types of loads in working condition.
- ii) **Seed Box:** It may be made of mild steel sheet or galvanized iron with a suitable cover. A small agitator is sometimes provided to prevent clogging of seeds.
- v) **Covering Device:** It is a device to refill a furrow after the seed has been placed in it. Covering the seeds are usually done by patta, chains, drags, packers, rollers or press wheels, designed in various sizes and shapes.
- Vi) **Transport Wheel:** There are two wheels fitted on the main axle. Some seed drills have got pneumatic wheels also. The wheels have suitable attachments to transmit power to operate seed dropping mechanism.



Seed-cum-Fertilizer drill

Study of Calibration of Seed Drill

Calibration of seed drill and seed-cum fertilizer drill The procedure of testing the seed drill for correct seed rate is called Calibration of seed drill. It is necessary to calibrate the seed drill before putting it in actual use to find the desired seed rate. Calibration is done to get a predetermined seed rate of the machine. Before using the seed drill or seed-cum fertilizer drill in the field, it is calibrated.

The following steps are followed for calibration of seed drill or seed-cum fertilizer drill.

5. Determine the nominal width (W) of drill

$W = M \times S$ where M is the number of furrow openers and S is the spacing between the openers in metre and W is in meter.

6. Find the length of a strip (L) having nominal width W necessary to cover 1/25th of a hectare.

$$L = 10000 / 25W = 400/W \text{ meter}$$

7. Determine the number of revolutions (N) the ground wheel has to make to cover the length of the strip(L).

$DN=10000$ Where D= D is diameter of ground wheel in meter

4. Jack up the drill so that the ground wheels turn freely. Make a mark on the drive wheel and a corresponding mark at a convenient place on the body of the drill to help in counting the revolutions of the drive wheel.

5. Put selected seed and fertilizer in the respective hoppers. Place a sack or a container under each boot for seeds and fertilizers.

6. Set the rate control adjustment for the seed and the fertilizer for maximum drilling. Mark this position on the control for reference.

7. Engage the clutch or on-off adjustment for the hoppers and rotate the drive wheel at the speed N

$$N = 400/ W \times D \text{ rev /min}$$

8. Weigh the quantity of seed and fertilizer, dropped from each opener and record on the data sheet.

9. Calculate the seed and fertilizer, dropped in kg/hectare and record on the data sheet.

10. Repeat the process by suitable adjusting the rate control till desired rate of seed and fertilizer drop is obtained.

Exercise No. 11

Aim:-To Study of Sprayers and Dusters

Sprayers:

Sprayer is a machine to apply fluids in the form of droplets. Sprayer is used for the following purposes:

- 1) Application of herbicides to remove weeds.
- 2) Application of fungicides to minimize fungus discuses.
- 3) Application of insecticides to control insect pests.
- 4) Application of micronutrients on the plants.

The main functions of sprayer are:

1. To break the liquid into droplets of effective size.
2. To distribute them uniformly over the plants.
3. To regulate the amount of liquid to avoid excessive application.

Desirable Quality of Sprayers:

- a. The sprayer should produce a steady stream of spray materials in the desired fineness of the particle so that the plants to be treated may be covered uniformly.
- b. It should deliver the liquid at sufficient pressure so that it reaches all the foliage and spreads entirely over the sprayed surface.
- c. It should be light in weight, sufficiently strong, easily workable and repairable.

Basic Components of Sprayer:

Components of a sprayer are as follows:

1. Nozzle body
2. Nozzle cap
3. Swirl plate
4. Spray gun
5. Spray boom
6. Filter
7. Over-Flow Pipe

8. Relief Valve
9. Pressure Regulator
10. Cut-off Valve
11. Nozzle Disc
12. Nozzle Boss
13. Nozzle tip
14. Spray lance

1. Nozzle Body: It is the main component on which other components of a nozzle fit.

2. Nozzle Cap: It is a component which retains the assembled parts in or on a nozzle body. The nozzle disc or tip may be integral with the cap.

3. Swirl Plate: It is the part of a cone nozzle which imparts rotation to liquid passing through it.

4. Spray Gun: It is a spray lance from which the spray is readily adjustable during the operation.

5. Spray Boom: It is a spray lance with spray nozzles fitted to a head, mounted at right angles to the lance.

6. Filter: It is a component to remove suspended matter larger than a predetermined size from fluid.

397. Over-Flow Pipe: It is a conduit through which excess fluid from a pump is by-passed by the action of a relief valve or pressure regulator.

8. Relief Valve: It is an automatic device which opens when the pressure of the fluid or gas reaches a pre-determined valve.

9. Pressure Regulator: It is an automatic device to control the pressure of fluid or gas within a range of settings.

10. Cut-off Valve: It is a mechanism between the pump and the nozzle to control the flow of liquid from the sprayer. This is operated by hand.

11. Nozzle Disc: It is a component containing the final orifice of a nozzle usually a cone nozzle.

12. Nozzle Boss: It is a lug on spray boom or spray lance to which a nozzle body or cap is screwed.

13. **Nozzle Tip:** It is a component containing the final orifice of a nozzle usually a fan nozzle.

14. **Spray Lance:** A hand-held pipe through which the liquid reaches the nozzle mounted at the free end.

Types of Spray:

Sprays may be: 1) High volume spray (more than 400 liters spray/ha), 2) Low volume spray (5 to 400 liters, per hectare), 3) Ultra low volume (ULV) Spray (less than 5 liters spray/ha.)

The selection of technique depends on type of vegetation, kind of pests and approach to the field.

1. **High Volume Spray:** The dilute liquids are applied by hydraulic machines. It consumes more time and labour.
2. **Low Volume Spray:** It uses air stream from a fan as a pesticide carrier with small quantities of liquid. There is saving of material and labour.
3. **Ultra-Lower Volume Spray:** ULV spraying can be defined as plant protection operation in which total volume of liquid applied amount to a few milliliters per acre. It is mainly used in air craft spraying.
4. **Foam Spraying:** In this system a foaming agent (chemical additive) is added to the spraying solution. The spray is passed through a special nozzle. This system is economical.

Ultra-Low Volume Sprayer:

The sprayer has a motor powered by 6 or 12 volt battery. To the motor is attached a spinning disc, having grooves or teeth and rotates at a very high revolution per minutes (4000-9000). The spinning disc receives the concentrated chemical from a plastic container having a capacity of 1 liter (approx.). Average droplet size varies between 35 to 100 microns. It is used for application of weedicide and for spraying small trees and crops.

Power Sprayer:

Power sprayers are operated usually with internal combustion engines. The prime mover capacity varies from 1 to 5 HP. The pressure pump is operated by a small power unit ensuring a constant steady pressure. They are operated at pressure from 20 to 55 kg/sq. cm. These machines are usually portable type. Sometimes, power sprayers are operated by the power take-

off (PTO) shaft of the tractor besides being pulled by it. Some sprayers are tractor mounted and PTO operated also.

A power sprayer essentially consists of:

- i) Prime mover
- ii) Tank
- iii) Agitator
- iv) Air-chamber
- v) Pressure gauge
- vi) Pressure regulator
- vii) Boom
- viii) Nozzles.

i. Prime Mover: Prime mover is needed to supply power to the power sprayer. It is usually internal combustion engine. The power generally varies from 1 to 5H.P.

ii Tank: Steel tank is widely used to prevent corrosion. Plastic tanks are also getting popular due to freedom from corrosion and ease of moulding into smooth shapes. A covered opening, fitted with a removable strainer is provided for easy filling, inspection and cleaning. A drain plug is there at the bottom of the tank for draining the liquid.

ii Agitator: Agitators are needed to agitate the liquid of the tank. Propeller or paddle type mechanical agitators are provided for agitating the liquid. Horizontal shaft may be used with flat blades rotating at about 100 to 120 rev/ min. Paddle up speeds in excess of 2.5 m/sec may cause foaming.

iv. Air Chamber: An air chamber is provided on the discharge line of the pump to level out the pulsations of the pump there by providing a constant nozzle pressure.

v. Pressure Gauge: The pressure gauge is provided on the discharge line to guide the operator regarding spray pressure. The spray pressure should be under specified limit.

vi. Pressure Regulator: It is meant for adjusting the pressure of the sprayer according to the requirement of the crops in the field.

vii. Strainer: A strainer is included in the suction line between the tank and the pump to remove dust, dirt and other foreign materials.

viii. Boom: Field sprayer to be driven by a tractor has a long boom in a horizontal place on which nozzles are fixed at specified spacing. The boom can be adjusted vertically to suit the height of plants in different fields.

ix. Nozzle: It is used to break the liquid into the desired spray and deliver it to plants.

A nozzle consists of:

- (a) body
- (b) Screw cap
- (c) Disc
- (d) Washer
- (e) Vortex plate
- (f) Strainer.

The body of the nozzle and the screw cap hold all the other parts in place. The disc has a number of holes including one hole in the center and they are usually numbered from one to ten to denote the diameter of the hole. Each number usually denotes about 0.4 mm. The disc needs replacement, when the holes get enlarged due to constant use. The washer under the disc is provided to prevent leakage of the liquid.

Spraying machines can be broadly classified into

1. Hand Operated Machines: Suitable for small holdings, they are operated at the pressures ranging from 1 to 7 kg/sq.cm.
2. Power Operated Machines: Suitable for treating a large area. They are operated at pressure from 20 to 55 kg/sq.cm.
3. Air planes: Suitable for large scale work.

Types of sprayers

1. Bucket Type Sprayer

This equipment consists of a single or double pump which may be placed into any ordinary bucket containing spraying solution. It is very light and easily handled and development sufficient pressure to spray small gardens and low trees.

2. Knapsack Sprayer

The common type of knapsack sprayer is provided with a pump and large air chamber permanently mounted in a 9 to 22.5 liters tank. The apparatus is quite useful for spraying small trees, shrubs and row crops. One man can spray about 0.4 ha. in a day thus spraying about 90 liters of liquid.

3. Compression Sprayer

It consists of an air pump mounted in an air tight chamber which is filled (3/4) the with spraying material. The pressure is developed by pumping air into the tank and the spray is forced out under pressure. The tank capacity is usually 14 liters and frequently pumping is to be done to maintain the pressure.

4. Hand Atomizer

This is the smallest type of hand sprayer used to treat the plants in home garden or nursery and to apply fly spray in the house. In this instrument compressed air is allowed to pass over the end of tube of which the other end dips into the spray material. Blowing air sucks the material through the tube and blows it out of the nozzles as mist.

5. Engine Powered Sprayers

These machines are usually portable types. Since the sprayer pump is driven by an engine there is no variation in output, pressure and performance of the P.T.O. shaft of the tractor besides being pulled by it.

6. Air Plane Sprayers

Either centrifugal pump or a gear pump is used to force the spray liquid through the nozzles. These pumps work at the pressure of about 2.8 to 8.5 kg/cm². The pump sets its driven from a wind driven propeller having four to six blades. The tank capacity may range between 450 to 2550 liters.

Problems

1. Taking pressure as 35 kg/cm², the suction volume Q is 25 lit/min and pump efficiency is 85 per cent. Calculate shaft horsepower
2. Find the suction capacity of power sprayer if diameter is 25 mm, speed is 1100 rpm, length of stroke is 22 mm, and number of plunger is 3.

Dusters

Duster is a machine to apply chemical in dust form. Dusters make use of air streams to carry pesticides in finely divided dry form on the plants. A duster essentially consists of a) Hopper b) Agitator c) Feed control d) Fan or blower and e) delivery nozzle.

Types of Duster:

There are several types of dusters in the common use, such as:

- 1) Plunger type
- 2) Knapsack type
- 3) Rotary type
- 4) Power operated duster.

1. Plunger Type:

It is a simple duster with a small piston. The piston drives a current of air over the dust in the hopper. The dust is carried away through a delivery spout. Small hand pump dusters of this type are available and are suitable only where the area to be dusted is small like vegetable or flower garden.

2. Knapsack Type Duster:

It is a duster with the powder container on the back of the operator. Knapsack dusters have a hopper through which a current of air is blown to pick up the dust. The air current is produced by lever operated leather blows. Shoulder straps or carrying straps are generally provided in such dusters and they can be easily carried in the fields. These dusters are suited for small areas only.

3. Rotary Duster:

It is a duster with a hand-operated rotor in front of the operator. For spraying tall crops, more force of delivery is required, hence rotary dusters are preferred. Dust is fed from a hopper into a current of air produced by a rotary fan and is blown out through a delivery pipe. Most of the models have stirring device, actuated by the fan crank to ensure a steady flow of dust. The rate of delivery can be regulated by a valve below the hopper. The delivery force is controlled by controlling the speed of the fan.

4. Power Operated Duster:

Power operated duster mainly consists of a power driven fan, a hopper and a delivery spout. The fan creates strong airflow, which causes the dust to blow off from the hopper to a considerable distance either vertically or horizontally. The direction of the dust is regulated by a movable delivery spout suitably fitted with the unit. These types of dusters are used for large areas.

Care and Maintenance of Dusters:

1. Duster should be thoroughly cleaned before and after use with suitable brush.
2. The hopper should be fitted with dust about half of its capacity.
3. The lid of the hopper should be closed during the operation.
4. In rotary dusters, handle should be cranked at 30 to 35 revolutions per minute for efficient performance.
5. Before storing the duster after use, the dust from the fan box, suction pipe and hopper should be thoroughly blown out and the agitation shaft should be profusely oiled while cranking.
6. Pieces of paper, sacking and other foreign materials should be prevented from getting into the hopper.
7. The agitator parts and dust feed should be occasionally checked for blockage by foreign matters.

Essential Spare Parts to Be Kept in Stock:

- i) Agitator,
- ii) Feed control lever,
- iii) Feeding brush,
- iv) Shaft for crank,
- v) Crank handle,
- vi) Hose couplings and clips,
- vii) Breast plate,
- viii) Nozzle,
- ix) Nuts and screws.

General Precautions for the Safe Use of Insecticides:

1. The name on container should be read carefully and manufacturer's instruction should be followed.
2. The pesticides should be kept always in container with proper name.
3. The pesticides should be stored in a safe and locked place so that children may not touch them.
4. The pesticides should never be placed near foodstuff or medicines.
5. Empty containers of dangerous pesticides should not be used for any alternative purpose.
6. Necessary protective clothing should be used while handling pesticides. The pesticide bags should not be torn but it should be cut with a knife.

Seed Dresser: It is a machine to apply coating of protective chemicals to seeds. Fumigator: It is a machine to generate and distribute gases or smoke.

Flame Gun: It is an apparatus to kill weeds by a flame.

Power Sprayer cum Duster: It is a power operated sprayer, which can be converted as duster when desired.

Exercise No. 12

Study of Inter-Culturing Tools and Implements –

Manual and Animal Drawn

The main objective of weed control are to improve the soil conditions for heal their growth of plant. Weeds growing along with crops complete for moisture, light and nutrients. Hence, it is essential to remove them.

Following are some of the weeding devices used by the farmers.

Type of weeding tools and implements:

- (1) Traditional hand tools.
- (2) Traditional and Improved hoes.
- (3) Wheel hoes.
- (4) Animal drawn multipurpose hoe.
- (5) Tractor drawn intercultural equipment.

(1) Traditional hand tools:

(i) **Khurpi** : Khurpi is a traditional hand tools and made by local artisans for the use on small and marginal farmers. Khurpi is used in India may vary in their size, shape and weight, but they have common basic part i.e. a cutting blade and a small wooden handle for the grip. The khurpi with a long narrow blade is preferred for weeding around the flower plants, broadcasted crops and vegetable crops. However, a man can weed outabout0.025 hectare in a day under normal condition.

(2) Traditional and Improved hoes:

The hoe is a versatile form of implements used for many operations i.e. seed bed preparation, ridge making, channel shaping and weeding. It is also for removing plant roots, harvesting root crops and thinning drilled crops.

The two common types of hoe used by Indian farmers are:

- (i) Hand hoes
- (ii) Animal drawn hoes.

Hand hoes are used to cultivate very small area of land by human labour. Among the indigenous type of hand hoes, the Kodali (narrow spade) is most popular one.

(i) Kodali: Kodali is similar to a phawara (broad spade), the difference being that instead of a wide thin cutting blade, a narrow long pointed thicker section blade is attached to the handle. The person working with it has to bend his body. It is used for inter cultivating maize and sugarcane crops, and for earthing up the potato crops sown in line. About 0.04 hectare can be covered in a day by one man.

33(ii) Improved hand hoe: An improved hand hoe is operated in the standing position. It is provided with the long handle fitted in the middle of the cutting blade. One end of the blade is about 10 cm wide sharp edges and the other end is pointed narrow one for making small furrows. It can be used for cultivating and weeding very close to the individual plant.

(iii) The Grubber: The grubber is a manual pull type hoe suitable for weeding and inters culture of upland row crops in black cotton soil region. It is provided with three blades and the field capacity is 1/200 ha. per hour.

(iv) Rotary paddy weeder: Rotary paddy weeder is best suited for uprooting the weed and burying them into soil. The operator moves the tools forward and backward in narrow rows of paddy crops. It gives higher output and drudgery of the operator is considerably reduced. (3) The wheel hoe:

The wheel hoe is another implement which is used for cultivating the land between rows. It consists of a wheel, two handles and a type to place the cutting tool on. Either a reversible shovel or a three prong fork or rake or sweep is used as a cutting tool, depending upon the weed and moisture condition. A man operates the hoe in standing position by pushing through a short length each time. In a working day, 0.04 hectare can be covered.

(4) Animal drawn hoe:

Animal drawn weeding implements are pulled either by single animal or a pair of animal. These implements may either be single row type or multi row unit.

The main parts of the blade hoe are: (i) Head piece (ii) Prong (iii) blade (iv) handle and (v) beam. The number of cutting blades on these hoes may be one or more. The prong make an angle of about 45° downward with the horizontal plane. At the end of each prong, the blade is attached. It

loosens the upper surface of the soil and is generally used for inter culturing sorghum, cotton, groundnut and other kharif crops. The hoe width is maintained between 25 and 75 cm depending upon the size of the bullocks and types of soil.

Exercise No. 13

Aim.-To Study of Harvesting and Threshing Machinery

Harvesting: It is the operation of cutting, picking, plucking, digging or a combination of these operations for removing the crop from under the ground or above the ground or removing the useful parts or fruits from plants.

Harvesting plants: The operation of cutting a plant is achieved by four different actions. (1) slicing action with a sharp smooth edge, (2) tearing action with a rough, serrated edge, (3) high velocity single element impact with sharp or dull edge, and (4) a two element scissor type action.

Sickle:

It is a simple harvesting tool. It is used for harvesting crops and cutting other vegetation's. It essentially consists of a metallic blade and a wooden handle. Blade is the main metallic part of the sickle. It is desirable to make the blade of carbon steel. It is made in a curved shape. The tooth of serrated sickle is made sharp for efficient working in the field. The handle of the sickle is made of well-seasoned wood.

Sickle

The forged end of the blade for fixing the handle is called tang. The plain or serrated edge in the inner side of the blade is called cutting edge. Protective metallic bush fitted at the junction of the blade and the handle to keep the tang tight in the handle is called ferrule. Harvesting by sickle is very slow and labour consuming device.

Reaper:

Animal drawn reaper: Reaper is a machine to cut grain crops. It is pulled by a pair of animals. It can harvest nearly 5 to 8 cm above the ground. The machine consists of frame, cutter bar, knife, wheels, bearings and other attachments. Frame is usually made of mild steel sections. The cutter bar knife is made of high carbon steel. The shoes are usually made of malleable casting. Usually two persons are required to operate the machine. One man guides the animals and another man is engaged in dropping the cut crops from platform to the ground.

Power thresher:

It is a machine operated by a prime mover such as electric motor, engine, tractor or power tiller used for threshing.

A power thresher performs several functions such as:

- i) To feed harvest to the threshing cylinder
- ii) To thresh the grain out of the head
- iii) to separate the grain from the straw
- iv) to clean the grain
- v) To put the grain in the bag
- vi) To make the chaff suitable for animal feeding

Types of Power threshers:

- i) Hammer mill type: It is a thresher with threshing unit consists of hammers or beaters with closed cylinder casing and concave. It is equipped with a set of oscillating sieves an aspiratory blower for separation and cleaning of grains.
- ii) Rasp-bar-cylinder type: In this thresher the threshing unit consists of bars with creations having an open concave

Power thresher

- iii) Spike- tooth type: In this thresher the threshing unit consists of drum having rows of spikes with closed cylinder casing and concave. It is equipped with a set of oscillating sieves an aspiratory blower for separation and cleaning of grains.

- iv) Syndicator type: In this thresher the threshing unit consists of a corrugated fly wheel with cerrated chopping knives and a closed cylinder casing and concave. This is also called as chaff cutter type thresher.

- 46v) Drummy type: It is a hammer mill type thresher without separation and cleaning unit.

On the basis of feeding system threshers are four types as:

- i) Feed thresher.
- ii) Conveyor feed thresher
- iii) Feed roller feed thresher
- iv) Hopper feed thresher

On the basis of crop threshers are six types as:

- i) Wheat thresher

- ii) Paddy thresher
- iii) Ground nut thresher iv) Millet thresher
- v) Soya bean thresher vi) Multi crop thresher

Components of Power Thresher:

- i) **Concave:** It is a concave shaped metal grating partly surrounding the cylinder against which the cylinder rubs the grain from the plant or earth heads and through which the grains fall on the sieve.
- ii) **Cylinder or Drum:** It is a balanced rotating assembly comprising rasp, beater bar or spikes on its periphery and their support for threshing the crop. There are five cylinders commonly used as: i) peg tooth or spike tooth cylinder ii) Rasp- bar cylinder iii) Angle bar cylinder iv) Loop type cylinder v) Hammer mill type cylinder
- iii) **Cleaning Unit:** The function of cleaning unit is to separate and clean the threshed grain. The cleaning unit mainly consists of two or more oscillating sieves, a fan and an air sucking duct known as aspirator. Usually two ducts are there, one primary and other secondary duct. The function of the primary duct is to remove major portion of straw, dust and other foreign matter. The secondary duct is used for final cleaning of the grains.

Threshing efficiency depends upon : i) Peripheral speed of the cylinder ii) Cylinder- concave clearance iii) Type of crop iv) Moisture content of crop v) Weather condition vi) Feed rate. Combine harvester:

Combine harvester: It is a machine designed for harvesting, threshing, cleaning and collecting the grain while it moves over the land. All the five operations are carried out in single operation of the harvester. The machine is versatile and with minor adjustments can handle a variety of crops. The size of the combine is indicated by the width of cut, it covers in the field.

Combine harvester in its primitive form was introduced in Germany and U.S.A. in late 19th century and became popular in next decades. In India, though a few tractor drawn combine harvesters manufactured by Minneapolis Moline U.S.A, and self-propelled Russian combine harvesters were available with some Govt. farms and landlords. However, between 1970-73 introduction of E512 GDR combine in Punjab, Haryana and M.P. was made in a big way. This was another revolution in the farm mechanization sector. Gradually indigenous production started with the manufacture of a Swaraj 8100 combine harvester in organized sector by M/s Punjab Tractors Ltd., which followed manufacturing of the

machine in small sector in a small way. Surprisingly in 30 years of its production on commercial scale in India there are 60 more manufacturers with a production capacity of 5 to 150 combines per year. On an average about 800 combines are added every year on Indian farms. All these manufacturing units are located in the state of Punjab.

Functions of combine harvester

1. Cutting the standing crops
2. Feeding the cut crops to threshing unit
3. Threshing the crops
4. Cleaning the grains from straw
5. Collecting the grains in a container

Problem No.1

Calculate the total time required to harvest 2.5 hectare of grass by means of a 2m mover operating at a speed of 4kmph. Take field efficiency of mover as 80%.

Solution:

$$\text{Actual Area covered, Ha, } A = [(W \times S) / 1000] \times (E / 100) \times \text{Time}$$

$$2.5 = [(200 \times 4) \times 80 / (1000 \times 100)] \times \text{Time}$$

$$\text{Time} = (2.5) / [(200 \times 4) \times 80 / (1000 \times 100)]$$

$$\text{Time} = 3.9 \text{ Hours}$$

Problem No. 2 :

What hp will be required to pull 1.2 m mover working at a speed of 4.8 kmph. If there is a load of 50 kg per meter length of the mover and mechanical efficiency is 80%.

Solution:

$$\text{Total load} = 1.2 \times 50 = 60\text{kg}$$

$$\text{Total Power} = \text{Draft (kg)} \times \text{Speed (kmph)} / 270 = (60 \times 4.8 / 270) = 1.066 \text{ hp}$$

$$\text{hp required to pull the mover} = (1.066 \times 100 / 80)$$

$$= 1.33 \text{ hp}$$